

Corvette C7

INSTALLATION MANUAL

Chevrolet Corvette C7 Bottom Line Style Front Splitter Installation Manual

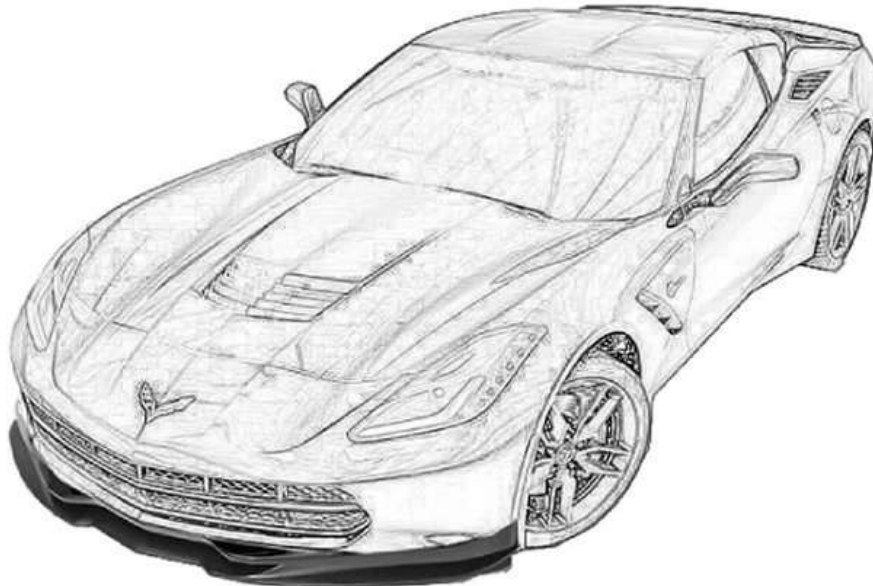

**READ CAREFULLY
BEFORE INSTALLATION**



WARNING!!! Please test fit the items before applying paint job.

We recommend 2 people for installation

Self-tapping screw
(provided)



Auto Double-Sided Mounting Tape
(not provided)



Car jack

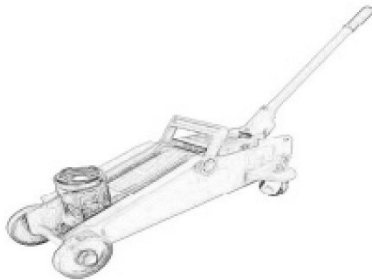

Socket Wrench

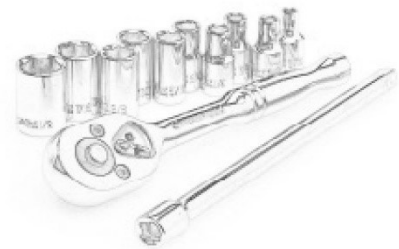

Screw Driver



Auto Cleaner



Impact Drive



Tips for protecting your lip after installation

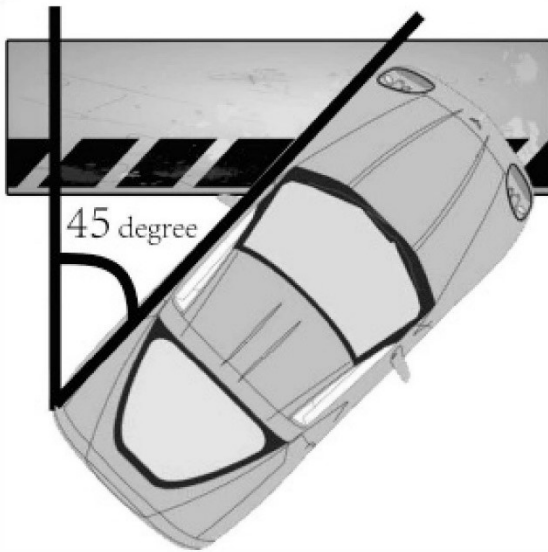

Take the approach at a 45 degree angle slowly when entering or leaving inclines/declines

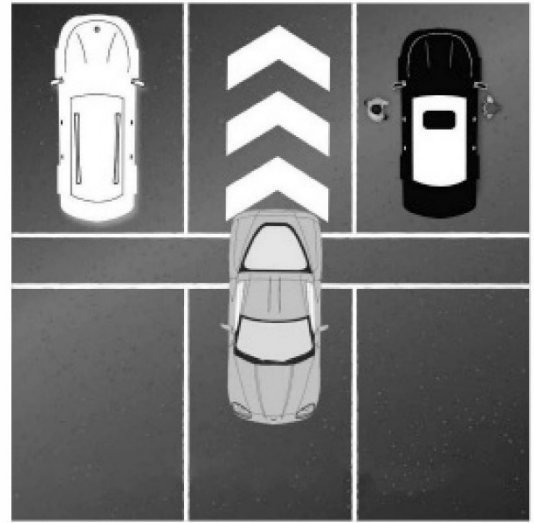

Always back up parking

1

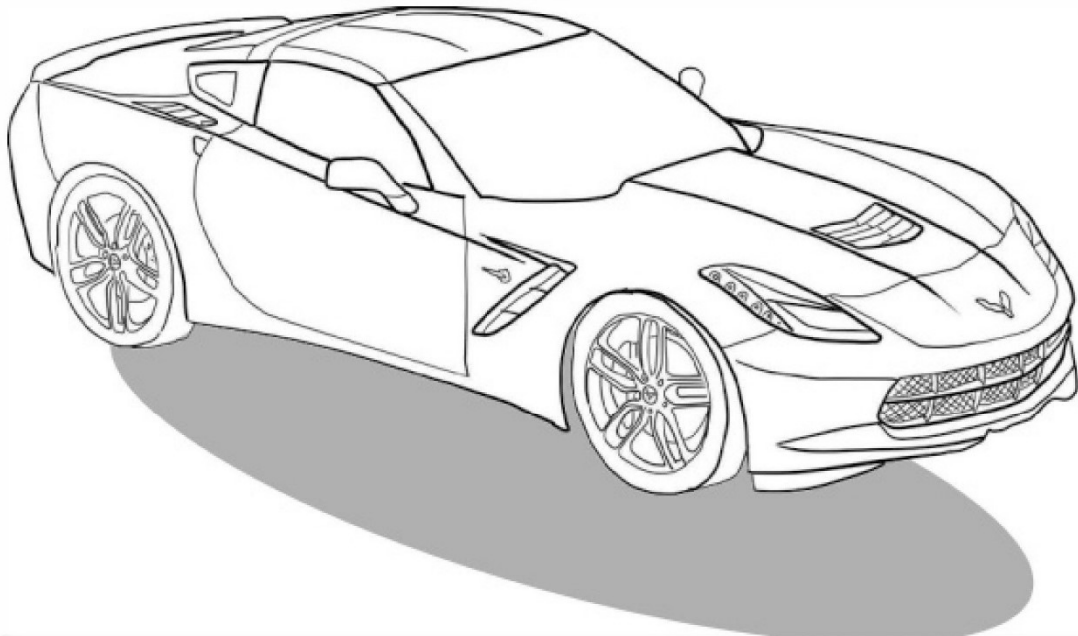

Raise vehicle to a comfortable working height

2

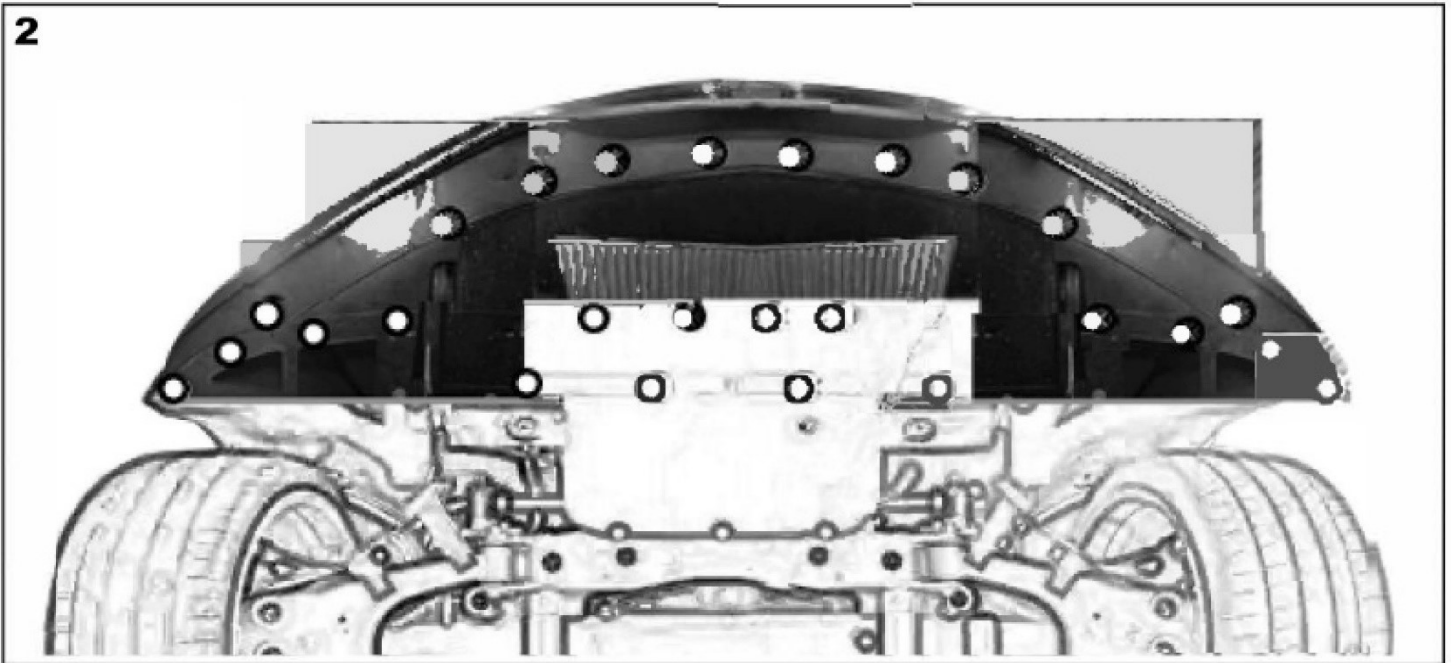

Use a 7MM socket to remove all the bolts (as shown in the picture)

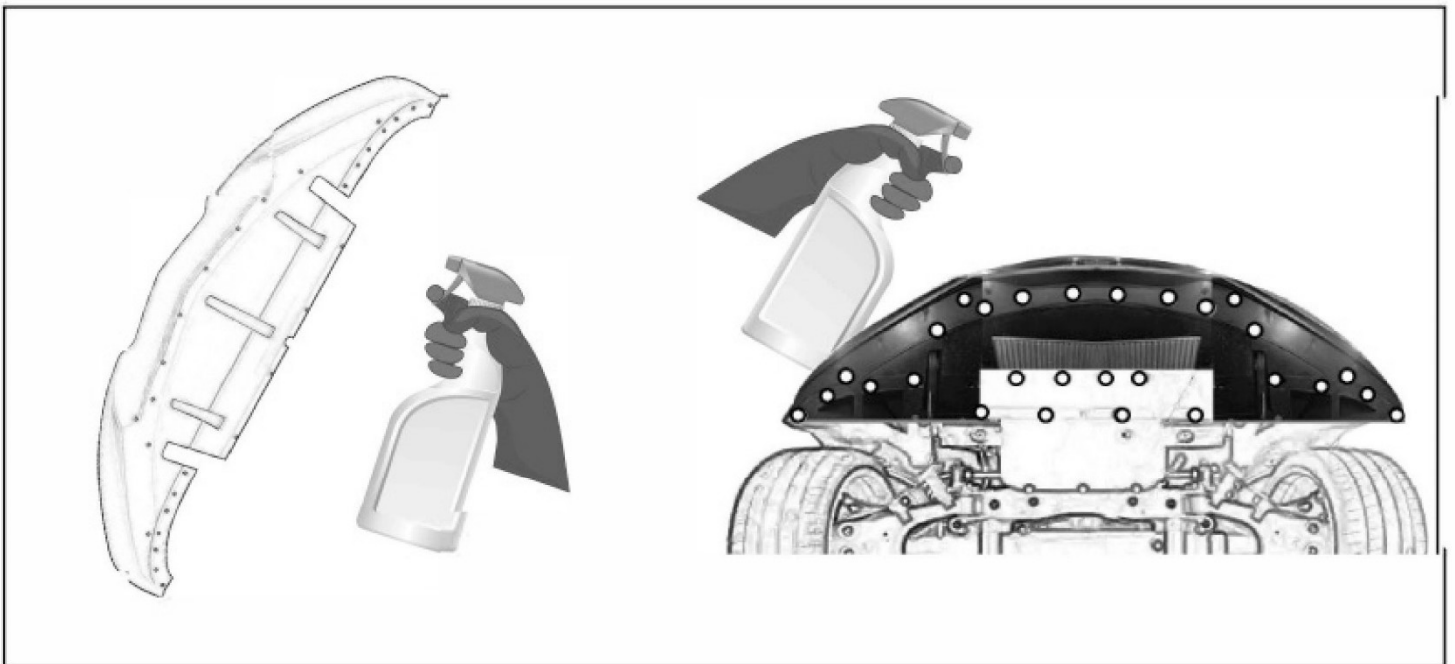

**Clean the painted surface of the original part on the car.
Ensure the underside portion is free of debris and residue**

4

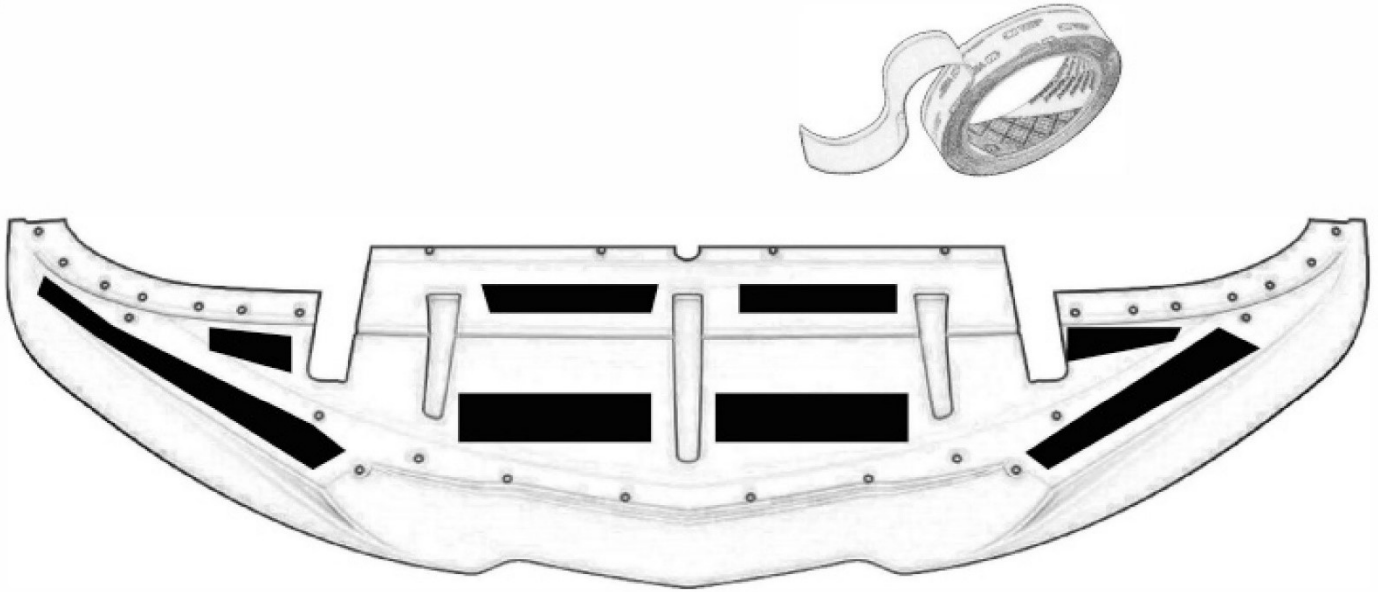

Attach 3M Double Sided Tape (as shown in the picture) onto the Front lip, avoid covering the Pre-drilled holes with the Tape.

5

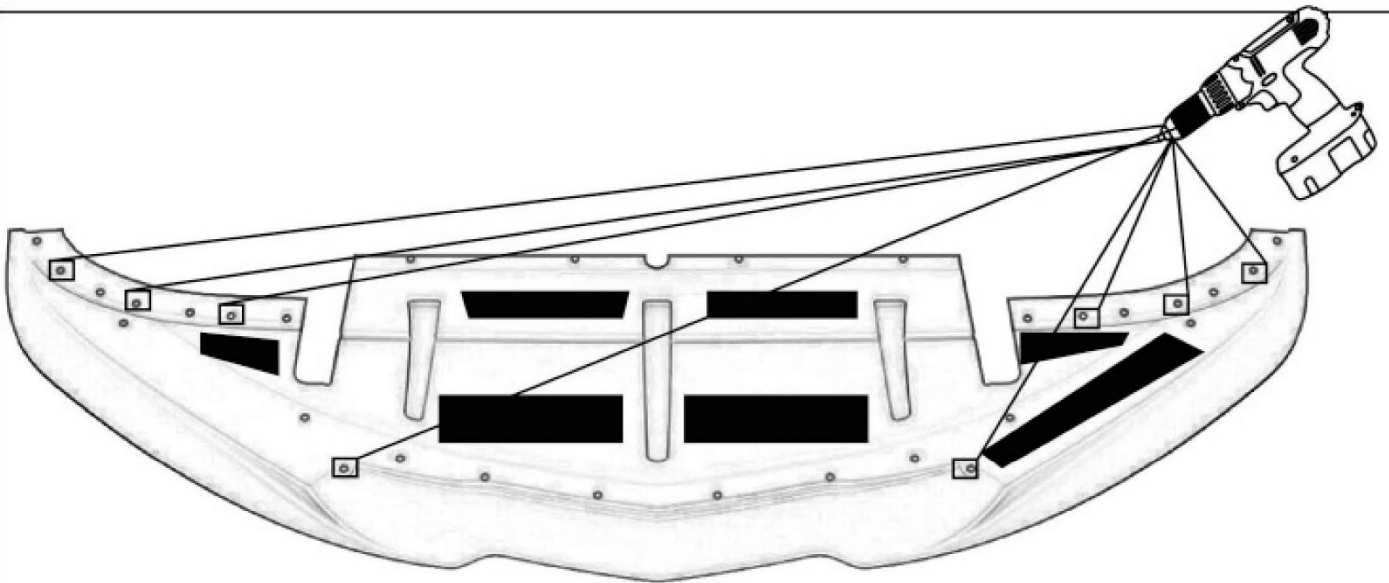

Drill the holes as shown in the picture

Tips for using 3M double side tape in installation

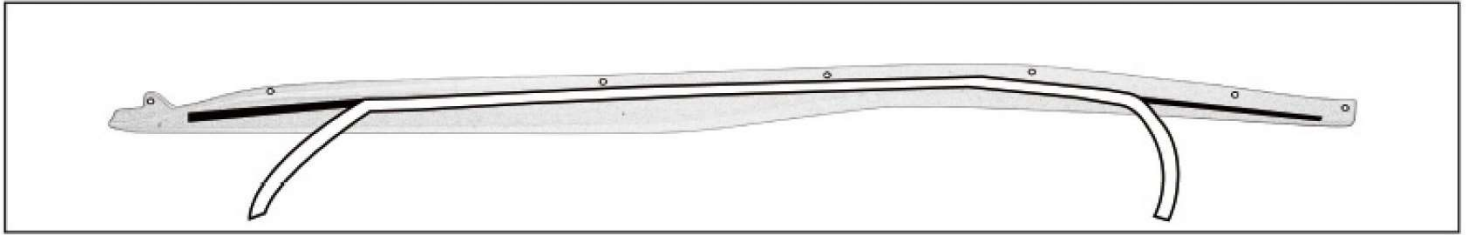

Please peel off the red strip on 3M tape on both ends

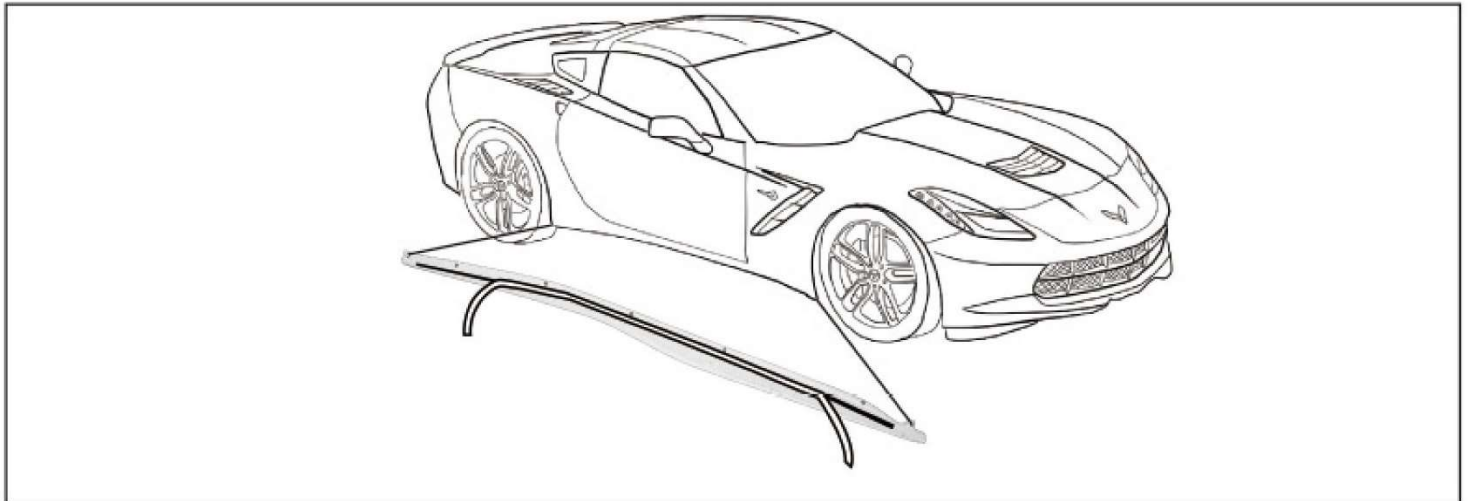

Then attach the EOS part onto your vehicle in place, make sure to check the alignment of the EOS parts.

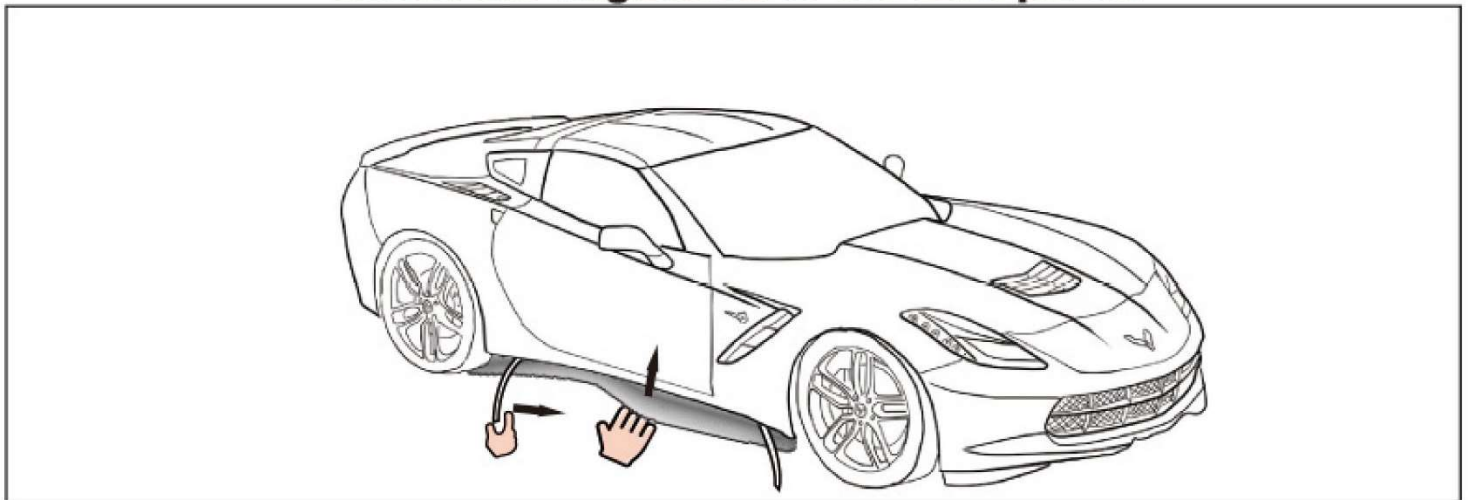

SLOWLY peel off the remaining 3M tape while applying pressure/hold it tight on the EOS part to the vehicle at the same time.

(Please note, this instruction applies for all of the EOS parts including Front Splitter and Rear Spoiler,etc)

6

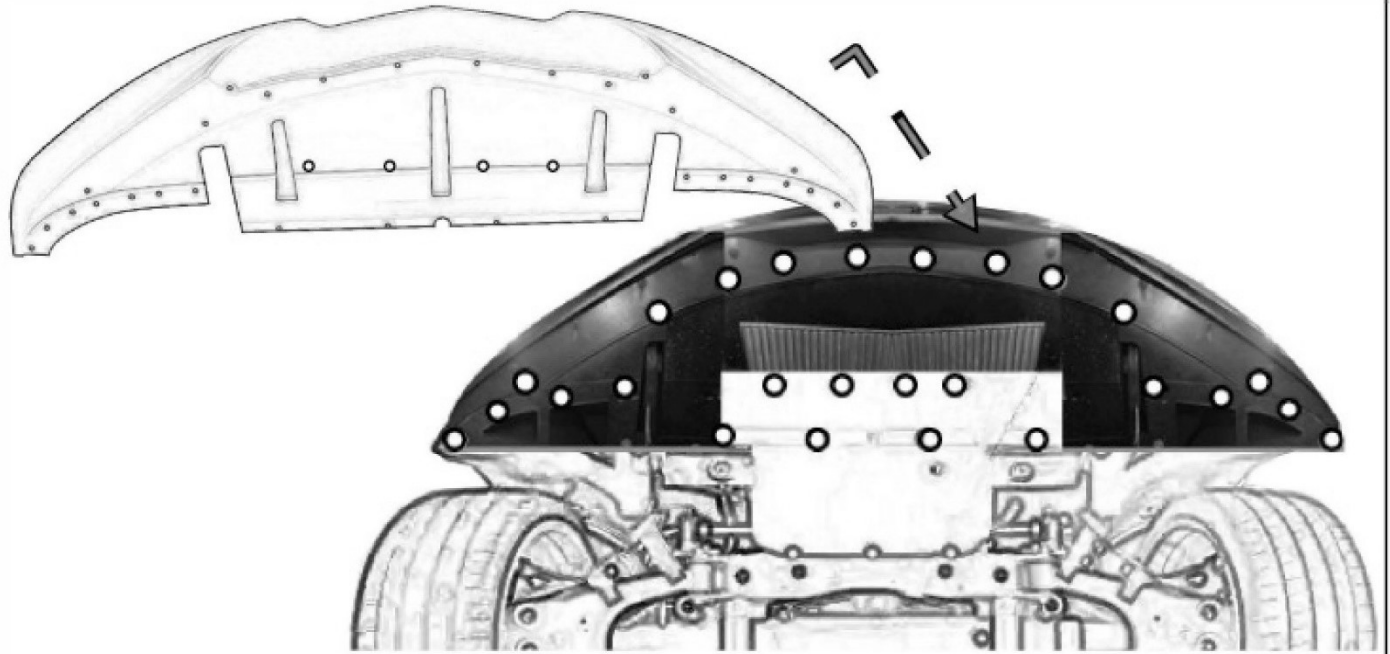

Reinstall OEM bolts from step2

7

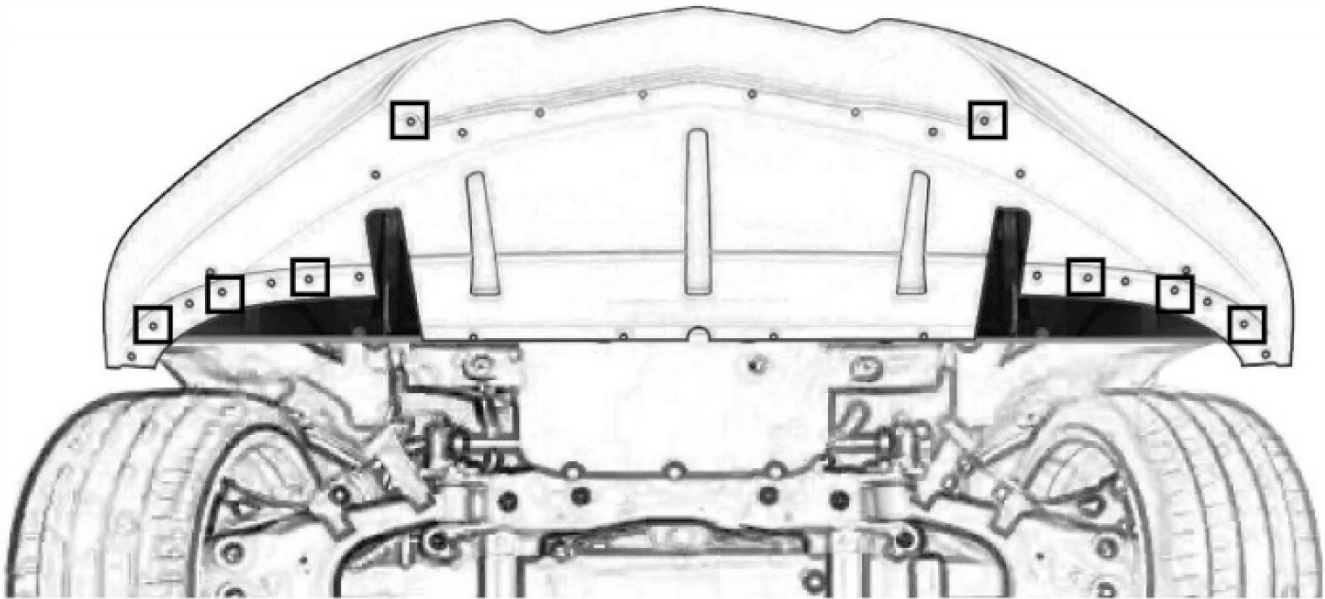

Now you have the lip holded on your vehicle. Then drill the holes indicated as square in the picture and install with bolts /rivets